

Power Doubler Amplifier

AS 1717



Sharp Vision AS 1717 is Professional Power Doubler Distribution Amplifier with dual output. A very high quality of RF signal can be obtained upto 860 MHz with Channel loading capacity of 106 channels. These amplifiers are used due to their high output level characteristics. These characteristics make them suitable for MSO and cable Operators having long trunk cabling and large number of subscribers. They are suitable for HFC networks.

A Necessity to be used as first amplifier in every Trunk Cable before distribution For High Output Level with high C/N (with low CSO/CTB).



Features:

- High output level
- Power Doubler O/P stage
- 46 ~ 860 MHz
- 106 Ch. Loading Capacity
- High Return Loss
- Plug-in Slope Card
- Dual Output with Excellent Flatness
- Good C/N, CSO, CTB Characteristics
- High Voltage Surge Protection
- Mains –cum- Power pass
- PP Voltage Selection LED

Specifications:

- Gain : 30dB
- Adjustable Gain : 0 ~ 20dB
- Output Level : 105dB μ V
- Slope (Fixed) : Standard 0dB
(Optional:9/12/15dB for 550/750/860MHz)
- Flatness : \pm 0.2dB
- Return Loss : > 14dB
- Noise Figure : < 7dB
- Mains Voltage : 220VAC \pm 10%, 50Hz
- Power Pass : 30/40/50/60 VAC

Use of just One AS 1717 instead of a Hybrid Amplifier at Input Stage 3dB – An Excellent Feature



An International Quality Product from **ANALOG SYSTEMS**

website: www.sharpvisiononline.in

Email: sales@sharpvisiononline.in / analogsystems@vsnl.net

Installation Guidance for AS 1717 & AS 1520 Amplifiers

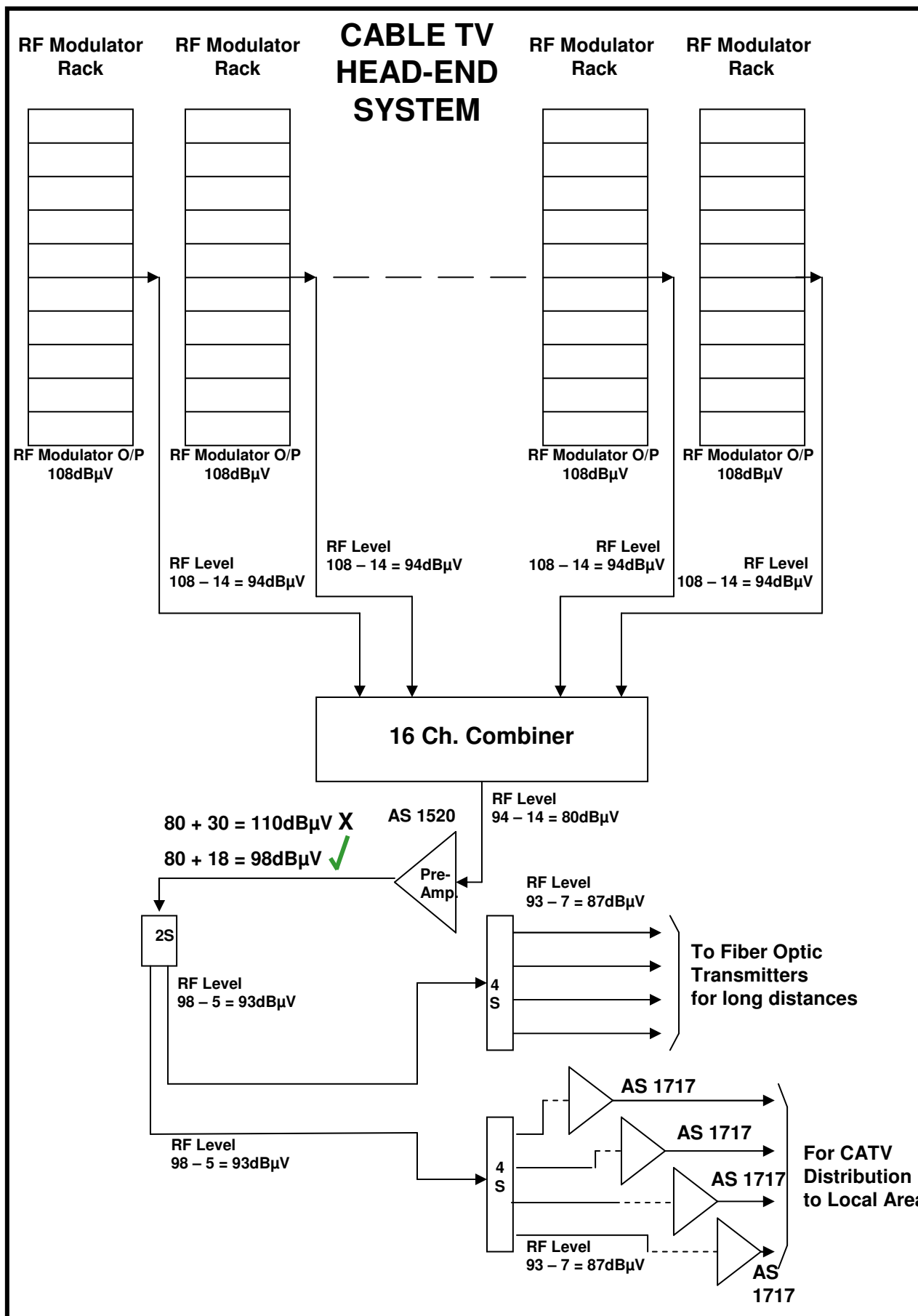

Installation guidance for Franchise Cable Operator

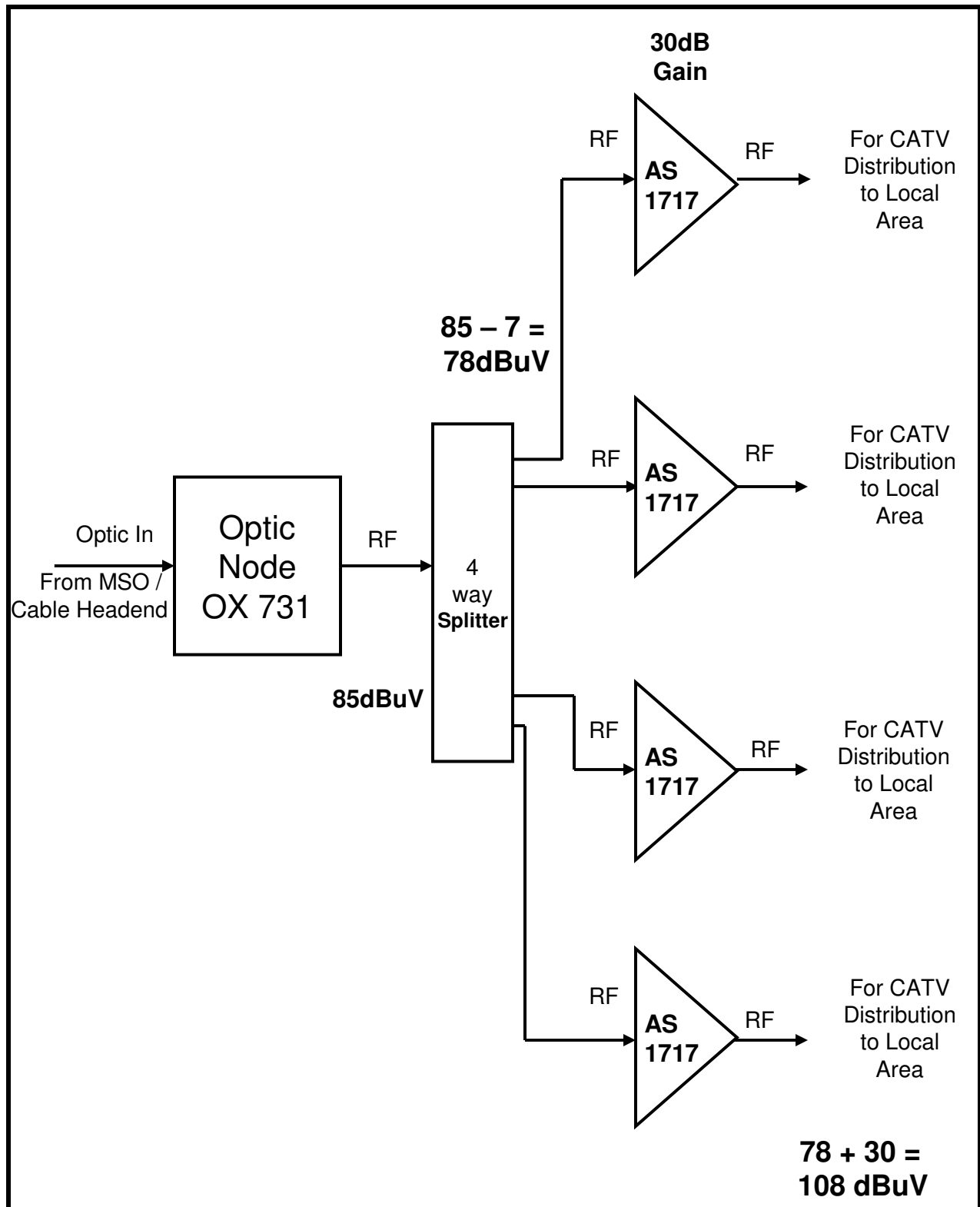

An International Quality Product from **ANALOG SYSTEMS**

website: www.sharpvisiononline.in

Email: sales@sharpvisiononline.in / analogsystems@vsnl.net

Choose The Right Amplifier For Your Cable System



	AS 1520	AS 1717	AS 1515 / AS 1111
1	Low Noise Pre-Amplifier	Power Doubler Distribution Amplifier	Trunk Line Amplifier
2	Gain : 18dB	Gain: 30dB	Gain: 28dB(with double o/p)
3	Output Level: 100dBuV @ 80Ch	Output Level: 105dBuV @ 80Ch	Output Level: 100dBuV @ 80Ch (single output)
4	Control Room Application To compensate Combiner Losses with high C/N (with low CSO/CTB).	A Necessity to be used as first amplifier in every Trunk Cable before distribution For High Output Level with high C/N (with low CSO/CTB).	To be used as a regular amplifier in the Trunk line
5	Suitable for Trunk Cables where low gain is required	Suitable for Long Trunk Cables with large number of subscribers	Suitable for Trunk Cables and Branch Cables
6	Medium Price	Price is comparatively high	Economical in Price



An International Quality Product from **ANALOG SYSTEMS**

website: www.sharpvisiononline.in

Email: sales@sharpvisiononline.in / analogsystems@vsnl.net